

DIY Block Target Stand

By: JR Bowhunting & Fitness



Facebook: @jrbowhuntingandfitness

Instagram: @jrbowhuntingandfitness

Twitter: @jrbowandfitness

www.jrbowhuntingandfitness.com

©2016 JR Bowhunting & Fitness

LIST OF MATERIALS

Qty	Description
2'	2" x 10"
12'	2" x 4"
1	Cinch / ratchet strap

NOTES

- Use Green treated lumber if you are planning on keeping this outside
- For the 2' x 10" x 24" top cross section piece that the target will sit on, you can mount that at any height you feel necessary. In the first picture I mounted it 2 feet up (for my kids) and in the picture at the end of this manual, I mounted it all the way at the top at 36" (for taller shooters)
- In the picture below (Figure A), in the stand I set lower, I attached the cinch / ratchet strap with #8 x 1" wood screws and 1/8" x 1" washers
 - I also ran the strap in between platform and the upright 2 x 4 to center it and keep it in place.

Figure A

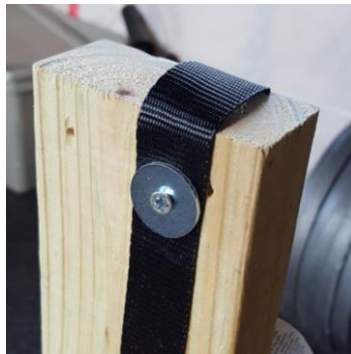

PLANS

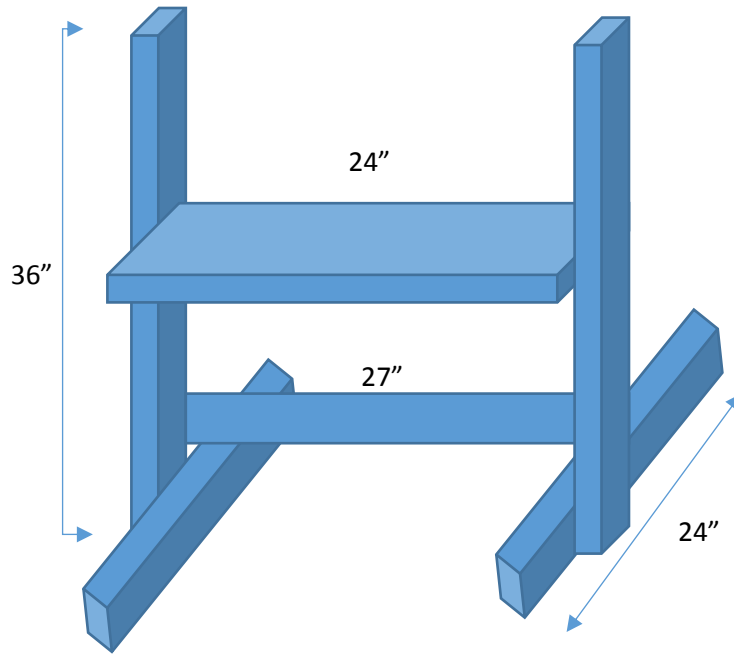

Facebook: @jrbowhuntingandfitness
Instagram: @jrbowhuntingandfitness
Twitter: @jrbowandfitness
www.jrbowhuntingandfitness.com
©2016 JR Bowhunting & Fitness



Facebook: @jrbowhuntingandfitness
Instagram: @jrbowhuntingandfitness
Twitter: @jrbowandfitness
www.jrbowhuntingandfitness.com
©2016 JR Bowhunting & Fitness